

NUVICO®

EASYVIEW™ *LITE*



EASYVIEW LITE
Dome Camera

Indoor CD Series

*For Vari-focal CD-H21N and CD-HD21N-L
(NTSC and PAL)*

INSTALLATION MANUAL

Disclaimer

- While every effort has been made to ensure that the information contained in this guide is accurate and complete, no liability can be accepted for any errors or omissions.
- NUVICO reserves the right to change the specifications of the hardware and software described herein at any time without prior notice.
- No part of this guide may be reproduced, transmitted, transcribed, stored in a retrieval system, or translated into any language in any form, by any means, without prior written permission of NUVICO.
- NUVICO makes no warranties for damages resulting from corrupted or lost data due to a mistaken operation or malfunction of the cameras, peripheral devices, or unapproved/un supported devices.

Warning and Caution

WARNING!

TO REDUCE THE RISK OF FIRE OR ELECTRIC SHOCK, DO NOT EXPOSE THIS PRODUCT TO RAIN OR MOISTURE. DO NOT INSERT ANY METALLIC OBJECTS THROUGH THE VENTILATION GRILLS OR OPENINGS ON THE EQUIPMENT.

CAUTION!



The lightning flash with arrowhead symbol, within an equilateral triangle, is intended to alert the user to the presence of uninsulated “dangerous voltage” within the product’s enclosure that may be of sufficient magnitude to constitute a risk of electric shock to persons.



The exclamation point within an equilateral triangle is intended to alert the user to the presence of important operating and maintenance (servicing) instruction in the literature accompanying the product.

Important Safeguards

- Read these instructions.
- Heed all warnings.
- Follow all instructions.
- Do not use this equipment near water.
- Clean only with dry cloth.
- Do not block any ventilation openings. Install in accordance with the manufacturer's instructions.
- Do not install near any heat sources such as radiators, heat registers, stoves, or other equipment (including amplifiers) that produce heat.
- Do not defeat the safety purpose of the polarized or grounding-type plug. A polarized plug has two blades with one wider than the other. A grounding type plug has two blades and a third grounding prong. The wide blade or the third prong is provided for your safety. If the provided plug does not fit into your outlet, consult an electrician for replacement of the obsolete outlet.
- Protect the power cord from being walked on or pinched, particularly at plugs, convenience receptacles, and the point where they exit from the equipment.
- Only use attachments/accessories specified by the manufacturer.
- Unplug this equipment during lightning storms or when unused for long periods of time.
- Refer all servicing to qualified service personnel. Servicing is required when the equipment has been damaged in any way, such as power-supply cord or plug is damaged, liquid has been spilled or objects have fallen into the equipment, the equipment has been exposed to rain or moisture, does not operate normally, or has been dropped.
- **CAUTION - THIS MANUAL IS FOR USE BY QUALIFIED SERVICE PERSONNEL ONLY. TO REDUCE THE RISK OF ELECTRIC SHOCK DO NOT PERFORM ANY SERVICING OTHER THAN THAT CONTAINED IN THE OPERATING INSTRUCTIONS UNLESS YOU ARE QUALIFIED TO DO SO.**
- Use Certified/Listed Class 2 power supply transformer only.

Table of Contents

Disclaimer	2
Warning and Caution	3
Important Safeguards	4
Table of Contents	5
Introduction / Available Models	6
Content Verification	7
Parts & Descriptions	8
Camera Dimensions	9
Installation	10
Connecting to Monitors	11
Adjusting the Vari-focal DC Auto Iris Lens	12
Adjusting the 3-Axis Gimbal	13
Switching OFF/ON the IR LED	14
Camera OSD Setup Controls	15
OSD Menu Terms & Settings	16
SETUP	16
1. LENS	16
2. EXPOSURE	16
(2.1) Shutter (2.2) Brightness (2.3) AGC (2.4) DWDR	17
3. WHITE BALANCE	18
(3.1) ATW1 (3.2) ATW2 (3.3) AWC (3.4) Manual	18
4. BACKLIGHT	19
(4.1) BLC (4.2) HLC	19
5. IMAGE ADJ.	20
(5.1) Lens Shad. (5.2) 2DNR (5.3) Mirror (5.4) Font Color	20
(5.5) Contrast (5.6) Sharpness (5.7) Display (5.8) Neg. Image	21
6. SPECIAL	22
(6.1) Cam Title	22
(6.2) Day&Night	23
(6.3) Motion	24
(6.4) Privacy (6.5) DPC	25
(6.6) Version	26
7. RESET / 8. EXIT	26
OSD Menu Tables	27
Technical Specifications	30

Introduction

ABOUT THIS MANUAL

Thank you for purchasing our EasyView™ Lite dome camera.

Our EasyView™ Lite Dome Cameras are all equipped with high resolution 1/3" Interline transfer CCD Imager for enhanced low-light sensitivity. Available in a host of different combinations, from standard fixed lens color domes, to vari-focal day/night domes equipped with IR LEDs, the EasyView™ Lite series cameras accommodate a broad range of applications and demanding environments. Now in 600TVL!

Before installing and using this camera, please read this manual fully and carefully, and be sure to keep it handy for later use. This installation manual covers the following models listed below. Any difference in features are indicated where necessary.

Available Models

FIXED LENS	INDOOR DOME CAMERAS
H Series 600 TVL	CD-H2N-I / CD-H2P-I (Ivory) CD-H2N-B / CD-H2P-B (Black)
HD Series 600 TVL • Day/Night • 30 IR LED	CD-HD2N-LI / CD-HD2P-LI (Ivory) CD-HD2N-LB / CD-HD2P-LB (Black)

VARI-FOCAL LENS	INDOOR DOME CAMERAS
H Series 600 TVL	CD-H21N-I / CD-H21P-I (Ivory) CD-H21N-B / CD-H21P-B (Black)
HD Series 600 TVL • Day/Night • 24 IR LED	CD-HD21N-LI / CD-HD21P-LI (Ivory) CD-HD21N-LB / CD-HD21P-LB (Black)

Content Verification

Before installing the camera, please make sure that all of the following items are included in the box.

EasyView™ Lite Dome Camera

1. EasyView™ Lite Dome Camera
2. Installation Manual
3. Mount Mounting Template
4. OSD Remote Controller - Model#: CA-ORC
5. Mounting Hardware

- **(x3) Philips ST4x30 Assembly Screws**

These screws are used to mount the Surface Mount Plate to a sturdy surface.

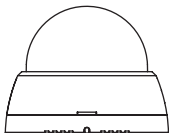

EasyView™ Lite Dome Camera

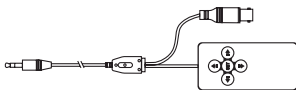

OSD Remote Controller
(CA-ORC)



Screws
(3pcs)

Mounting Template Sticker

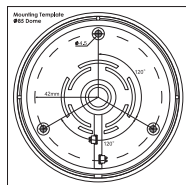
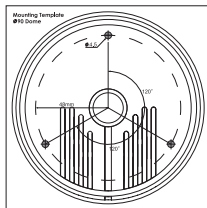

Parts & Descriptions

- 1 Bubble
- 2 Dome Cover
- 3 Mounting Screws
Philips ST4x30 (Indoor & Vandalproof)
- 4 Camera Module
- 5 Lens
- 6 Dome Base
- 7 Service Monitor Output (OSD Control Port)
Model #: CA-ORC (Vari-focal Only)
- 8 Power Cable & Video
12VDC/24VAC Dual Voltage (Vari-focal Only)

Vari-focal Lens Models (24VAC/12VDC)



Fixed Lens Models (12VDC)

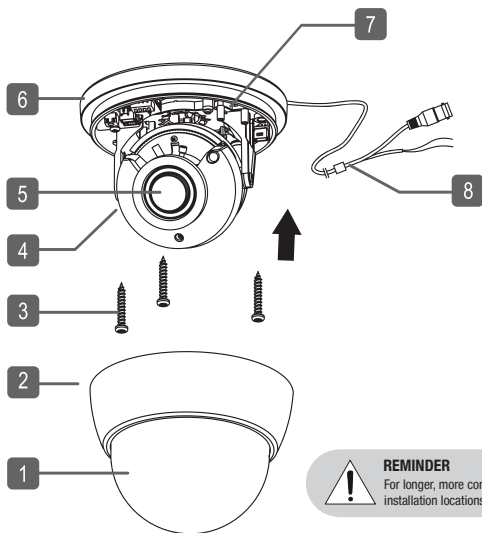
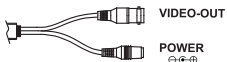

REMINDER

For longer, more consistent performance, avoid installation locations prone to direct sunlight.

Camera Dimensions

See the diagrams below for the exact dimensions of the EasyView™ Lite dome camera.

Dimensions Unit: Inches (mm)

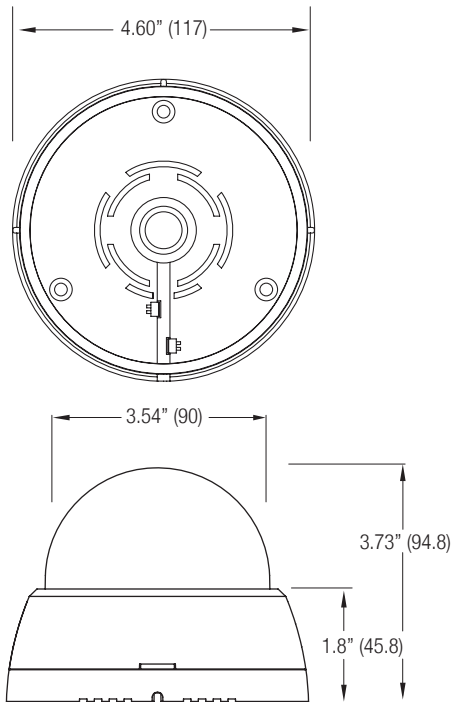

Installation

1. Following the illustration to the right, place the template sticker to the desired location. Then using the three screws provided with package, secure the camera base to the wall or ceiling as shown.
2. Make the appropriate power and video connections.
3. Adjust the 3-axis gimbal and point the camera to the desired area. Place the dome cover over the base and push firmly until it snaps into place.

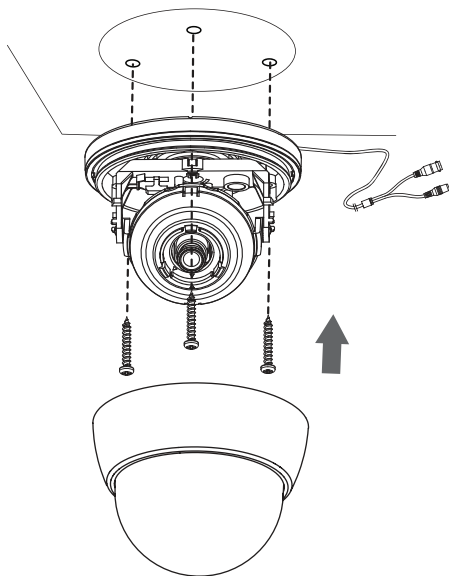

Connecting to Monitors

Follow the diagram below to make proper connections to the CRT Monitor or the Service Monitor.

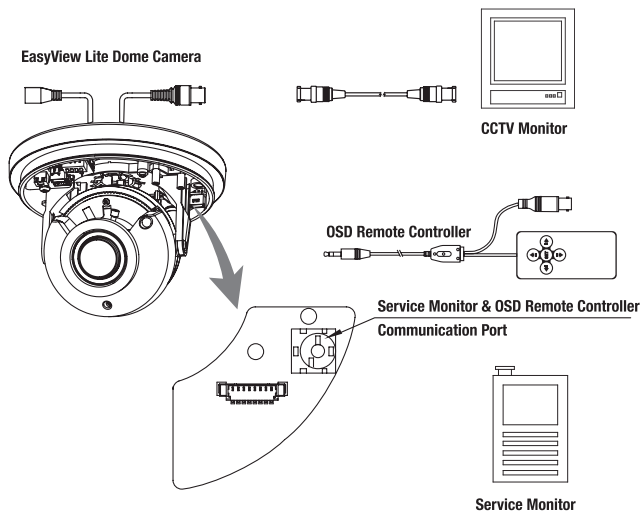

- Power connection (Auto polarity detection and protection) - 12VDC/24VAC Dual Voltage on Vari-focal Lens models, otherwise 12VDC Voltage for Fixed Lens models.
- Service monitor outputs are located on the Camera Power Board, and are only available in the EasyView™ Lite dome cameras equipped with a Vari-focal lens. To make changes in the OSD menu, please use the OSD Controller provided with your camera purchase.

Adjusting the Vari-focal DC Auto Iris Lens

Follow the instruction provided below to make any lens adjustments.

1. Loosen the Zoom & Focus levers by rotating them counter-clockwise.

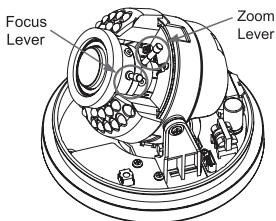

2. Adjust the Field of View by moving the Zoom lever towards the right (Wide) to zoom in or towards the left (Tele) to zoom out.

3. Once the desired zoom has been achieved, rotate the lever clockwise to lock it in place, and to prevent any future unwanted shifting.

4. Adjust the Focus the same way by moving the Focus lever to the right (Near) or to the left (infinity) until the picture is sharp and perfectly focused.

5. Lock the Focus lever in place by rotating the lever clockwise, then close the dome cover to finish installation.

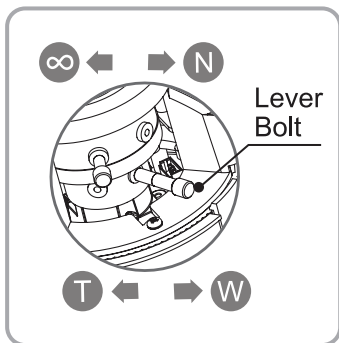

Adjusting the 3-Axis Gimbal

The Gimbal mechanism yields maximum rotation and placement as shown below.

- ❶ **Z-Axis:** Rotation 355°
- ❷ **Y-Axis:** Tilting 75°
- ❸ **X-Axis:** Panning 355°

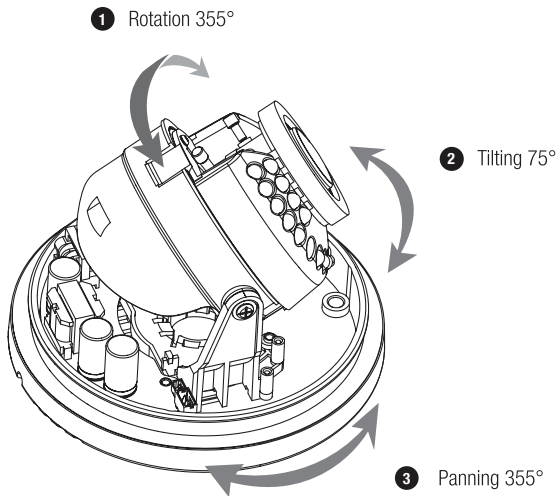

Switching OFF/ON the IR LEDs

IR LED Dip Switch

This Dip Switch is used to switch OFF/ON the IR LEDs.

Too much IR reflection from a subject causes over-exposure on the most focused area causing 'Hot Spots' within the picture. Adjust this setting can help avoid such problems.

- **OFF:** Select the OFF setting if the subject in the picture has extreme IR LED reflection.
- **ON:** Select the ON setting if the subject in the picture has no IR LED reflection.

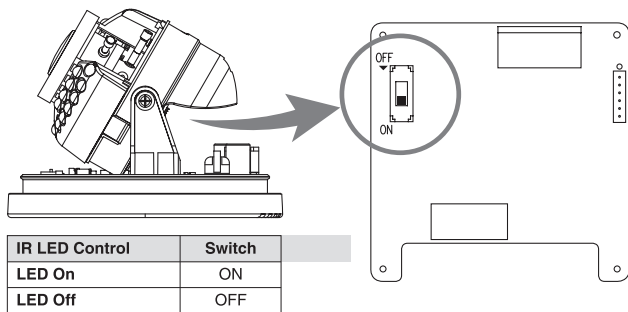

Camera OSD Setup Controls

OSD Controller and Service Cable

Gain access the dome camera OSD setup controls using the controller provided with your new camera shown at the right.

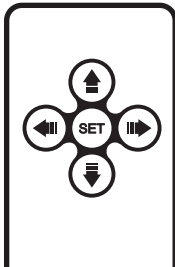
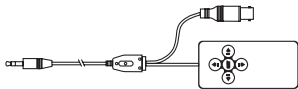

Set Key - Used to access MAIN SETUP menu mode.

Up / Down Key - Used to scroll through the desired sub-menu selection and to move the cursor up or down during the OSD menu.

Left / Right Key - Used to adjust the desired menu selection, and to move the cursor left or right. It is also used to confirm the setting changes.

Entering and Navigating the Main Menu

To enter the main menu, press the Set Key down once.

Entering and Navigating the Sub-Menu

To enter the sub-menu from the Main menu, press the **Left / Right** key at the selected line. While in the OSD menu, scroll up/down the available options by using the corresponding navigational keys.

Go to the Up-Menu from the Sub-Menu

To go to the up-menu from the sub-menu, press the **Left / Right** Key at the RETURN line.

Exiting the OSD Menu

Once all of the desired changes have been made, move the cursor over to the EXIT line to save and exit.

OSD Menu Terms & Settings

SETUP

The Setup is used to control and adjust the many features and options available on your dome camera. Read thoroughly before making any adjustments. *Note: These options have been pre-configured at the factory for optimal performance. Altering these settings is not recommended.*

SETUP	
LENS	DC
EXPOSURE	↵
WHITE BAL.	ATW1
BACKLIGHT	OFF
IMAGE ADJ.	↵
SPECIAL	↵
RESET	↵
EXIT	

1. LENS

This is always set on DC and cannot be changed. The EasyView™ Lite dome camera with Vari-focal lens are all DC Auto Iris lens.

2. EXPOSURE

EXPOSURE	
SHUTTER	AUTO
BRIGHTNESS	051
AGC	-----
DWDR	ON ↵
RETURN	RET ↵

OSD Menu Terms & Settings

2. EXPOSURE (Continued..)

2.1 SHUTTER (AUTO, FLK, 1/60 ⇐ - ⇒ 1/100,000)

The SHUTTER speed can be selected manually to user preference. Typically, to track fast moving objects across your screen, a faster shutter speed is used. The shutter speed of 1/60(NTSC), or 1/50(PAL) seconds are recommended.

- **AUTO:** Select the AUTO mode for automatic adjustment of the shutters. It will slow down or speed up depending on the environment.
- **FLK:** Select the FLK mode if the screen flickers due to differences in light and electric frequencies.

2.2 BRIGHTNESS (0 ~ 255)

The BRIGHTNESS can be adjusted by opening and closing of the Iris aperture. User may fine-tune the screen to their preferred brightness. The brightness ranges from 0~255 - 0 being the darkest and 255 being the brightest possible.

2.3 AGC - Automatic Gain Control (Off, Low, Middle, High)

This function is used to amplify the video signal when it falls below the set parameter. As the AGC level increases, the overall screen gets brighter but the level of Noise is increased.

Note: *The AGC feature cannot be modified while Day&Night mode is set to AUTO (under "Special"). By factory default, AGC is automatically set on "High."*

2.4 DWDR - Digital Wide Dynamic Range (On, Off)

Wide Dynamic Range works to correct excessive light within the frame to produce a usable image. It works by calculating the ratio between the brightest and darkest values of the picture and determines the balanced medium.

2.5 RETURN (Ret, End)

Select RET to go back to the main menu. Select END to save and exit.

OSD Menu Terms & Settings

3. WHITE BALANCE

This function is used to control the white balance under different lighting conditions. Adjusting this setting calibrates the camera for correct color rendering. *The factory default of 'ATW1' is recommended for optimal performance.*

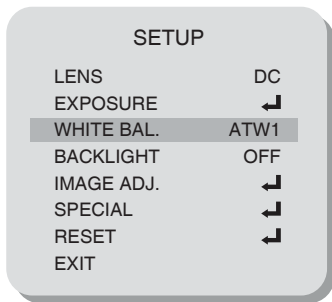

3.1 ATW1- Auto Tracing White Balance

Select the ATW1 mode to automatically adjust the color temperature according to its ambient condition.

3.2 ATW2

Select the ATW mode if the color temperature of the light source is between 1,800°K to 10,500°K (i.e. Fluorescent Light, Sodium Vapor Lamps)

3.3 AWC - Auto White Balance Control

Use the AWC function to correctly calibrate the white balance of the camera. While in this mode, press the Set key while placing a white sheet of paper in front of the camera. Repeat this procedure if there is a change in location or light source.

3.4 MANUAL (Indoor, Outdoor, Manual)

MANUAL function is to manually adjust the color temperature. Choose from Indoor, Outdoor, or the Manual mode. The Blue and Red values can be adjusted independently only in the Manual mode.

OSD Menu Terms & Settings

4. BACKLIGHT

This function is used to compensate for exposure problem associated with extremely bright backgrounds causing the subjects to bloom or silhouette.

BLC	
AREA SEL.	AREA1
AREA STATE	ON
GAIN	147
HEIGHT	010
WIDTH	009
LEFT/RIGHT	003
TOP/BOTTOM	003
RETURN	RET ↵

HLC	
LEVEL	155
MODE	ALL DAY
RETURN	RET ↵

4.1 BLC - Back Light Compensation

The BLC divides the frame and calculates exposure levels of each zone to counterbalance excessive background light in order to distinguish the subject in the foreground. There are 2 white boxes representing the areas affected by BLC. Each boxes can be individually adjusted to user preference.

- **AREA SEL. (Area1 ~ Area2):** Choose one of two pre-defined boxes to adjust its size or location.
- **AREA STATE (On, Off):** Select a box active or inactive for BLC.
- **HEIGHT/WIDTH:** Adjust the height or width of the area.
- **LEFT/RIGHT/TOP/BOTTOM:** Changes the location of the defined area.
- **RETURN:** Select RET to save and exit, and to go back to the MAIN MENU.

4.2 HLC - High Light Compensation

The HLC masks out excessively bright areas within the frame and compensates the rest accordingly.

- **LEVEL (0~255):** Choose the intensity of the HLC.
- **MODE (ALL DAY, ONLY NIGHT):** Choose the preferred mode. ALL DAY keeps the HLC mode on day or night, and ONLY NIGHT only during night-time recordings.

OSD Menu Terms & Settings

5. IMAGE ADJ.

IMAGE ADJ.	
LENS SHAD.	ON ◀
2DNR	ON
MIRROR	OFF
FONT COLOR	◀
CONTRAST	126
SHARPNESS	026
DISPLAY	CRT ◀
NEG. IMAGES	OFF
RETURN	RET ◀

5.1 LENS SHAD. (0~255)

Convex shape of the lens causes the light to enter the camera unevenly and typically makes the center of the screen brighter than the rest. Adjusting this setting will compensate for this undesirable effect and make the screen more even.

5.2 2DNR - Digital Noise Reduction (On, Off)

The DNR improves picture quality by filtering out signal noise associated with night-time recording. DNR compares pictures from a frame with the one previous and removes noise grains not present before.

5.3 MIRROR (On, Off)

This function is used to inverse (mirror) the pictures coming from the camera.

5.4 FONT COLOR

Change the OSD menu font color to user preference when there isn't enough contrast between the picture and the menu to distinguish the letters.

- FONT: Choose from the 15 available colors.
- ID & TITLE: Choose from the 15 available colors.

OSD Menu Terms & Settings

5. IMAGE ADJ. (Continued..)

5.5 CONTRAST (0~255)

Use the CONTRAST function to adjust the contrast in the picture.

5.6 SHARPNESS (0~31)

Use the SHARPNESS function to adjust the sharpness of the picture.

5.7 DISPLAY (CRT, LCD, USER)

CRT monitors will often display pictures brighter than LCD monitors. Selecting the correct type of viewing monitor will ensure the most optimal picture brightness.

5.8 NEG. IMAGE (On or Off)

This function reverses the pictures to view in inverse. Light to dark and vice versa.

5.9 RETURN

Select RET to save and exit, and to go back to the MAIN MENU.

OSD Menu Terms & Settings

6. SPECIAL

The Special Setup is used to control the CAMERA TITLE, DAY& NIGHT, MOTION, PRIVACY, DPC, and display the VERSION number of the dome camera.

SPECIAL	
CAM TITLE	OFF
DAY&NIGHT	AUTO ↵
MOTION	OFF
PRIVACY	OFF
DPC	↵
VERSION	00 00 00
RETURN	RET ↵

6.1 CAM TITLE (On, Off)

The CAMERA TITLE is used to assign a number or a custom title to easily identify between the many cameras that may be connected to your DVR or network.

Follow the simple procedure below to program the Camera ID.

1. Press the Left or Right key to turn ON the Camera Title mode.
2. While Camera ID function is ON, Press the Set key to enter the sub-menu.
3. Using the directional navigation keys, choose from alphabetical letters and numbers to create a 15-digit Camera ID.
4. Move the cursor to POS and press the Set key. The Camera ID will appear on the bottom center.
5. Using the directional navigation keys, change the position of the Camera Title to the desired location.
6. Move the cursor to END, then press the Set key to save and exit.

OSD Menu Terms & Settings

6. SPECIAL (Continued..)

6.2 DAY&NIGHT (AUTO, COLOR, B/W, EXT)

This function is used to control the color setting during daytime and night-time operation.

- **AUTO:** The Color mode is operated during daytime and automatically converts to B/W mode in the absence of light during night-time. *(AGC cannot be modified in this mode)*

D&N AUTO

D→N LEVEL	154
D→N DELAY	3 SEC
N→D LEVEL	112
N→D DELAY	5 SEC
RETURN	RET ↙

D→N Level - This level determines the level of darkness before switching from Day mode to Night mode.

D→N Delay - This function is used to set the delay between switching of the modes. If the delay has been set to '5,' the camera will observe darkness for at least 5 seconds before switching to Night mode.

N→D Level - Opposite of D→N Level.

N→D Delay - See above. D→N Delay.

- **COLOR:** The camera is always in Color mode, even during night-time operation.
- **BW:** The camera is always in BW (black and white) mode.

D&N B/W

BURST	OFF
IR SMART	ON ↙
IR LEVEL	HIGH
RETURN	RET ↙

BURST - This function smooths out noise in BW mode, and also makes the transition between switching of the modes smoother (Color to BW).

IR Smart - This function detects too much IR reflection and automatically compensates for the over exposure. Specific area can be defined by adjusting the location and size of the detection grid.

IR Level - This function is used to increase or lower the IR LED intensity.

- **EXT:** This feature is not supported.

OSD Menu Terms & Settings

6. SPECIAL (Continued..)

6.3 MOTION (On, Off)

This function is used to detect motion in the monitored area. The “Running Man” icon will be displayed on the bottom left corner once motion has been detected. There are 4 pre-defined white boxes representing the areas monitored for motion. Each boxes can be individually adjusted to user preference.

MOTION	
AREA SEL.	AREA1
AREA STATE	ON
HEIGHT	004
WIDTH	004
LEFT/RIGHT	002
TOP/BOTTOM	002
DEGREE	038
VIEW	ON
RETURN	RET ↩

- **AREA SEL. (Area1 ~ Area4):** Choose one of four pre-defined boxes to adjust its size or location.
- **AREA STATE (On, Off):** Select a box active or inactive for motion detection.
- **HEIGHT/WIDTH:** Adjust the height or width of the area.
- **LEFT/RIGHT/TOP/BOTTOM:** Changes the location of the defined area.
- **DEGREES (0~255):** Increases or decreases the sensitivity of the selected area. Increasing the number decreases sensitivity.
- **VIEW (On, Off):** Turns the “Running Man” indication on or off.
- **RETURN:** Select RET to save and exit, and to go back to the MAIN MENU.

OSD Menu Terms & Settings

6. SPECIAL (Continued..)

6.4 PRIVACY (On, Off)

This function is used to mask specific areas within the frame of the camera to be concealed. There are total of 8 different colored boxes representing the masked areas. Each boxes can be individually adjusted to user preference.

PRIVACY	
AREA SEL.	AREA1
AREA STATE	ON
HEIGHT	032
WIDTH	032
LEFT/RIGHT	020
TOP/BOTTOM	016
COLOR	000
RETURN	RET ↵

- **AREA SEL.**(Area1~Area8): Choose one of 8 colored boxes to adjust its size or location.
- **AREA STATE (On, Off)**: Select a box active or inactive for privacy masking.
- **HEIGHT/WIDTH**: Adjust the height or width of the area.
- **LEFT/RIGHT/TOP/BOTTOM**: Changes the location of the defined area.
- **COLOR (1~15)**: Choose one of 15 colors for the masked area.
- **RETURN**: Select RET to save and exit, and to go back to the MAIN MENU.

6.5 DPC - Dead Pixel Compensation

This function is used to compensate for the dead pixel areas of the screen. When a defective pixel is detected, a neighboring pixel information is used to determine the approximate pixel data and is replaced. The DPC is capable of compensating up to 64 points of dead pixels.

OSD Menu Terms & Settings

6. SPECIAL (Continued..)

6.6 VERSION

The camera firmware version is displayed here.

6.7 RETURN

Select RET to save and exit, and to go back to the MAIN MENU.

7. RESET

This function is used to reset all camera settings to the factory default setting.

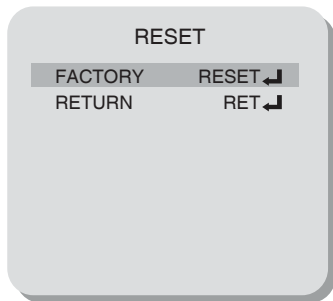

8. EXIT

Choose EXIT to save and exit from the MAIN MENU.

OSD Menu Tables

OSD Menu At A Glance

Use this section of the manual to get quick reference of the OSD menu. Please refer to the previous section for the detailed explanation of the features mentioned below.

MAIN MENU	CONFIGURATION			
LENS	DC			
EXPOSURE	SHUTTER	Auto, 1/60, FLK, 1/250, 1/500, 1/1000, 1/2000, 1/4000, 1/10000		
	BRIGHTNESS	0~255		
	AGC	Off, Low, Middle, High		
	DWDR	On/Off		
	RETURN	RET/END		
WHITE BAL.	ATW1			
	ATW2			
	AWC->SET	AWC->SET (PUSH)		
	MANUAL	Color Temp.	Manual	
		Blue	0~255	
		Red	0~255	
		Return	RET/END	
		Color Temp	Indoor	
		Blue	–	
		Red	–	
		Return	RET/END	
		Color Temp.		
		Blue		
	Red			
Return				

OSD Menu Tables

MAIN MENU	CONFIGURATION		
BACKLIGHT	OFF	Area Sel	Area1/Area2
	BLC	Area State	On/Off
		Gain	
		Height	
		Width	
		Left/Right	
		Top/Bottom	
		Return	
	HLC	Level	0~255
		Mode	All Day
Night Only			
Return	RET/END		
IMAGE ADJ.	LENS SHAD.	On/Off	
	2DNR	On/Off	
	MIRROR	On/Off	
	FONT COLOR	Font	0~15
		ID & Title	0~15
		Return	RET/END
	CONTRAST	0~255	
	SHARPNESS	0~31	
	DISPLAY	CRT	PED Level(0~63)
			Color Gain(0~255)
			Return(RET/END)
		LCD	GAMMA(0.05~1.00)
			PED Level(0~63)
			Color Gain(0~255)
	DISPLAY	USER	GAMMA(0.05~1.00)
			PED Level(0~63)
Color Gain(0~255)			
Return(RET/END)			
NEG. IMAGE			
RETURN			

OSD Menu Tables

MAIN MENU	CONFIGURATION			
SPECIAL	CAM TITLE	On/Off		
	DAY&NIGHT*	Auto/Color/BW/Ext		
	MOTION	Area SEL.	Area1~Area4	
		Area State	On/Off	
		Height	0~15	
		Width	0~15	
		Left/Right	0~15	
		Top/Bottom	0~15	
		Degree	0~255	
		View	On/Off	
		Return	RET/END	
		PRIVACY	Area SEL.	Area1~Area8
	Area State		On/Off	
	Height		0~15	
	Width		0~15	
	Left/Right		0~15	
	Top/Bottom		0~15	
	Color		0~15	
	Return		RET/END	
	DPC	Auto Defect (64 point)		
	VERSION	00,00,01		
RETURN	RET/END			
RESET	FACTORY	RESET		
	RETURN	RET/END		
EXT				

(*) Asterisk indicates features not available in the standard vari-focal lens model.
 DAY&NIGHT function is supported in the LED equipped models only.

Technical Specifications | NTSC

Technical Specifications	CD-H21N	CD-HD21N-L
Video Format	NTSC/PAL	
Image Sensor	1/3" CCD	
Horizontal Resolution	600 TV Lines	
Day/Night Functionality	No	Yes w/ ICR
Lens Type	Vari-focal 2.8mm-11mm	
Angle of View	134°(W) ~ 36°(T)	
IR LED	N/A	24
IR LED Distance	N/A	Up to 50ft.
LED Illumination Angle	N/A	80°
Sync System	Internal	
Effective Pixels	768(H) x 494(V)	
Scanning System	525 Lines. 2:1 Interlaced	
Electronic Shutter	1/60 sec.	
Main Video Output	1.0 Vp-p Composite, 75 ohm	
Service Monitor Output	1.0 Vp-p Composite, 75 ohm	
Minimum Illumination	0.2 Lux (Color)	0.2 Lux (Color), 0.00 Lux (B/W, IR LEDs On)
S/N Ratio	More than 48dB (AGC Off)	
General Information	CD-H21N	CD-HD21N-L
Operating Temperature	23°F ~ 113°F (-5°C ~ +45°C)	
Operating Humidity	Within 90% RH	
Power Consumption	500mA (Camera Only)	1 Amp (LED On), 500mA (Camera Only)
Input Voltage	12VDC/24VAC Dual Voltage	

*Specifications are subject to change without any prior notice.

Technical Specifications | PAL

Technical Specifications	CD-H21P	CD-HD21P-L
Video Format	NTSC/PAL	
Image Sensor	1/3" CCD	
Horizontal Resolution	600 TV Lines	
Day/Night Functionality	No	Yes w/ ICR
Lens Type	Vari-focal 2.8mm-11mm	
Angle of View	134°(W) ~ 36°(T)	
IR LED	N/A	24
IR LED Distance	N/A	Up to 50ft.
LED Illumination Angle	N/A	80°
Sync System	Internal	
Effective Pixels	752(H) x 582(V)	
Scanning System	625 Lines. 2:1 Interlaced	
Electronic Shutter	1/50 sec.	
Main Video Output	1.0 Vp-p Composite, 75 ohm	
Service Monitor Output	1.0 Vp-p Composite, 75 ohm	
Minimum Illumination	0.2 Lux (Color)	0.2 Lux (Color), 0.00 Lux (B/W, IR LEDs On)
S/N Ratio	More than 48dB (AGC Off)	
General Information	CD-H21P	CD-HD21P-L
Operating Temperature	23°F ~ 113°F (-5°C ~ +45°C)	
Operating Humidity	Within 90% RH	
Power Consumption	500mA (Camera Only)	1 Amp (LED On), 500mA (Camera Only)
Input Voltage	12VDC/24VAC Dual Voltage	

*Specifications are subject to change without any prior notice.

NUVICO®

Tel: 201-541-1605 Fax: 201-541-1620
Toll Free: 866-523-1700
E-mail: techsupport@nuvico.com
www.nuvico.com

EasyView™ Lite and the NUVICO logos are registered trademarks of NUVICO.
© Copyright 2009, NUVICO. All rights reserved.

Version 1.0